

NELSON STUD WELDING

SPECIFICATION: F3L Flanged Collar Stud

F3L studs are used as anchors to secure various refractory materials. Their most common use is for attachment of curved refractory blocks to steel skid tubes in steel mills. Wires are wrapped under the collars and around the blocks.

Cast, troweled, or gunned refractory is also applied over Nelson F3L studs. Various lengths of F3L studs are available, and are produced to accommodate different thickness of block or applied refractory.

For similar function studs, see Nelson CKL Collar Stud.

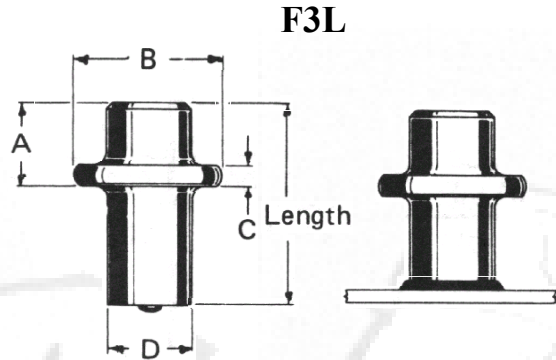

When ordering, specify Type, Description, Material, Quantity, and Part Number

Example: F3L 3/8 x 1-1/2"; Mild Steel; 10,000 pieces; #101041004

Stud Description	Stud Diameter D	A	B	C	Ferrule*	Required Standard Accessories		
						Grip	Chuck Assembly	Foot**
1/2 x L	0.500	0.500	0.875	0.125	100101119	501001012	500001014	502001137

* Ferrule used to weld 3" diameter pipe 100102026.

** 502001138 foot is used with standard duty guns. 502001002 foot is used with heavy duty guns.

MATERIALS: Studs are available in Low Carbon Mild Steel and 18-8 Stainless Steel. For specific grade information and physical and chemical properties, conforming standards, and information on stud plating and heat treating, please see [General Material Specifications](#).

FLUX: All Nelson F3L studs have a solid flux load.

Visit our website www.NelsonStudWelding.com for a list of our standard stock products.