

NELSON STUD WELDING

SPECIFICATION: CKL Collar Studs



CKL

CKL collar studs are used to mount circuit boards and panels where a stand off is desired. They are also used to retain cables or hoses using a clip. The thread extension speeds assembly over installing a bolt into an internal threaded boss or tapped stud.

The ferrules supplied with CKL studs have gripping neck diameters larger than the collar diameter, G. This allows the gun to strip straight off the welded studs.

For similar function, see Nelson **B5L 90° Bent Collar Studs**, **Banding Cable Hangers**, **CKA Aluminum Collar studs**, **CrimpLok™ Cable Hangers**, **Grounding studs**, **SBA Aluminum Shoulder Stud**, and **SBL Shoulder Stud**.

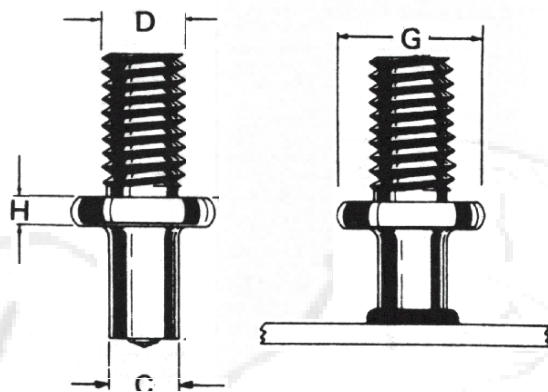

When ordering, specify **Type**, **Base Diameter**, **Base Length**, **Thread Size**, **Thread Length**, **Material**, **Quantity**, and **Part Number**

Example: CKL 0.330 x 1.125", 3/8-16 x 0.750"; Mild Steel; 10,000 pieces; #101015077

Thread Size	C	Minimum Base Length L	G	H	Required Standard Accessories			
					Ferrule	Ferrule Grip	Chuck	Foot
10-24	0.160	0.490	0.375	0.093	100101006	501001009	500001005	502001137
10-32	0.165	0.490	0.375	0.093	100101006	501001009	500001005	502001137
1/4-20	0.215	0.500	0.500	0.093	100101066	501001011	500001007	502001138
5/16-18	0.275	0.500	0.562	0.093	100101073	501001011	500001009	502001138
3/8-16	0.330	0.500	0.625	0.093	100101083	501001011	500001011	502001138
1/2-13	0.445	0.500	0.750	0.093	100101118	501001012	500001014	502001138

Ferrule footplates can be used in place of ferrule grips and feet when welding CKL studs.

Thread Size	Foot Plate
10-24	501006005
10-32	501006005
1/4-20	501006007
5/16-18	501006007
3/8-16	501006007
1/2-13	501006008

MATERIALS: Studs are available in Low Carbon Mild Steel and 18-8 Stainless Steel. Other materials are available by special order. For specific grade information and physical and chemical properties, conforming standards, and information on stud plating and heat treating, please see **General Material Specifications**.

THREADS: Standard threads are UNC-2A Course thread prior to any plating, 3" maximum length. Other threads, and thread lengths greater than 3" are available as special order.

FLUX: All Nelson CKL studs have a solid flux load.

Visit our website www.NelsonStudWelding.com for a list of our standard stock products.